



# 1343NdU

Nominal Diameter	6.5 " / 17 cm
Rated Impedance	8
Sensitivity	90 dB SPL
Power Handling Capacity	100 W AES
SPL max (continuous)	107 dB SPL
Usable frequency range	40 - 4000 Hz
Speaker net mass	1.34 kg

# 6.5 inches bass driver



## Architecture highlights :

- Phase plug version of SP1362NdU
- High excursion half roll rubber surround
- High definition ultra light CCAR Voice coil
- Natural convection Intercooler System
- Both side coated curvilinear cone

## Motor architecture

Magnet material	-	Nd
Voice coil diameter	mm	38
Voice coil length	mm	16
Air gap height	mm	6

## Typical characteristics

Rated impedance	Z	Ω	8
Half space sensitivity (1W@1m)	-	dB SPL	90.0
Usable freq. range	-	Hz	40 - 4000
Power handling capacity (AES)	-	W	100
Max Sound Pressure Level	SPL <sub>max</sub>	dB SPL	107
Min. impedance modulus	Z <sub>min</sub>	Ω@Hz	6.5@400
Voice-coil inductance @ 1kHz	Le <sub>1k</sub>	mH	0.624
Voice-coil inductance @ 10kHz	Le <sub>10k</sub>	mH	0.217
BL product	BL	N/A	8.1
Moving mass	Mms	kg	0.0133

## Thiele-Small parameters

Resonance frequency	Fs	Hz	40 (±5)
DC Resistance	Re	Ω	5.8 (±0.6)
Mechanical quality factor	Qms	1	4.82
Electrical quality factor	Qes	1	0.29
Total quality factor	Qts	1	0.28
Suspension compliance	Cms	10 <sup>-6</sup> .m/N	1200
Effective piston area	Sd	m <sup>2</sup>	0.0133
Equivalent Cas air load	Vas	m <sup>3</sup>	0.0299
Max linear excursion	Xmax	mm	± 5.0
Linear displacement volume	Vd	10 <sup>-3</sup> .m <sup>3</sup>	0.0664
Reference efficiency	η <sub>0</sub>	%	0.6
Unity load volume	Vas.Qts <sup>2</sup>	10 <sup>-3</sup> .m <sup>3</sup>	2.3

## Absolute maximum ratings

Short term max. input voltage	Vmax	V	55
Max.excursion before damage	Xdam	mm	± 10.0
Ambient operating temperature	Ta	°C	-10 to +50
Storage temperature		°C	-20 to +70
Environmental withstanding			tropical

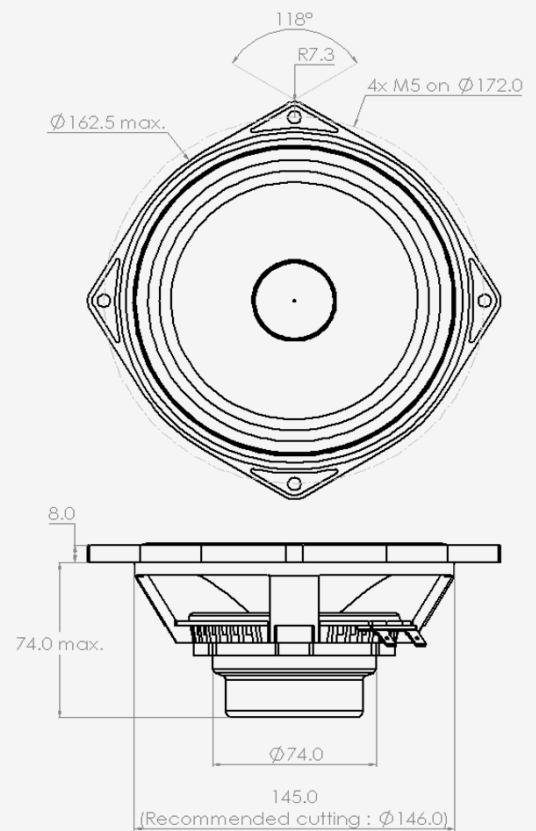

## Mounting information

Air volume occupied by the driver	10 <sup>-3</sup> .m <sup>3</sup>	0.37
Speaker net mass	kg	1.34
Baffle cut-out diameter (front mounting)	mm	146.0
Bolt number & Metric diameter	-	4x M5
Bolt circle diameter	mm	172.0
Max overall dimension (on ears)	mm	187.5
Max overall dimension (out of ears)	mm	162.5
Flange height	mm	8.0
Max magnet diameter	mm	74.0
Max depth (front mounting)	mm	74.0
Recommended reflex box	Lts / Hz	-
Electrical connection		6.35x0.8 FASTON



# 1343NdU

# 6.5 inches bass driver

SPL curves measured on CEI standard baffle :

- . at 25 cm, normalised 1 m
- . at 1 m for reference
- . Graph amplitude = 60 dB (PHL Audio standard)



HD curve measured on CEI standard baffle :

- . at 1 meter
- . at power =  $P_{AES} / 4$
- . Graph amplitude 0.01 % to 100 % (PHL Audio standard for  $P_{AES}/4$ )

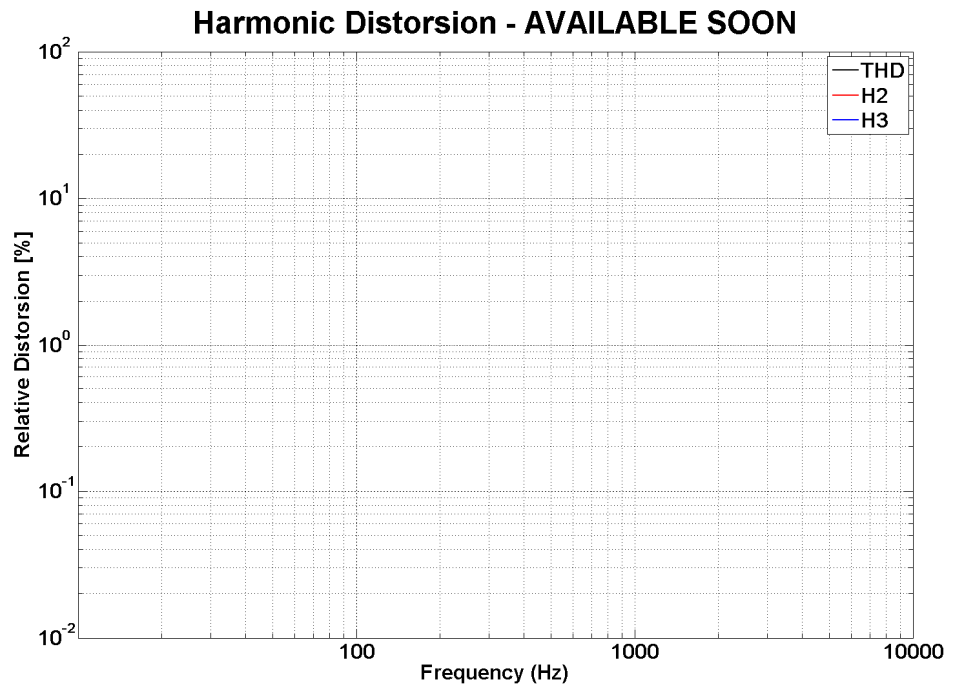

Non linear curves measured thanks to Klippel software and hardware, in free air

