



1660NdM

Nominal Diameter	6.5" / 17 cm
Rated Impedance	8
Sensitivity	96 dB SPL
Power Handling Capacity	250 W AES
SPL max (continuous)	117 dB SPL
Usable frequency range	300 - 5000 Hz
Speaker net mass	1.50 kg

6.5" midrange driver



Architecture highlights :

- Midrange unit with critical damping diaphragm
- Ultra light vented CCAR voice coil
- Natural convection Intercooler System
- High efficiency ultra low THD neodymium magnet system
- Low profile with flat motor

Motor architecture

Magnet material	-	Nd
Voice coil diameter	mm	51
Voice coil length	mm	11
Air gap height	mm	8

Typical characteristics

Rated impedance	Z	Ω	8
Half space sensitivity (1W@1m)	-	dB SPL	96.0
Usable freq. range	-	Hz	300 - 5000
Power handling capacity (AES)	-	W	250
Max Sound Pressure Level	SPL _{max}	dB SPL	117
Min. impedance modulus	Z _{min}	Ω@Hz	6.0@650
Voice-coil inductance @ 1kHz	Le _{1k}	mH	0.746
Voice-coil inductance @ 10kHz	Le _{10k}	mH	0.317
BL product	BL	N/A	12.5
Moving mass	Mms	kg	0.0130

Thiele-Small parameters

Resonance frequency	Fs	Hz	125 (±25)
DC Resistance	Re	Ω	5.2 (±0.5)
Mechanical quality factor	Qms	1	4.08
Electrical quality factor	Qes	1	0.34
Total quality factor	Qts	1	0.31
Suspension compliance	Cms	10 ⁻⁶ .m/N	120
Effective piston area	Sd	m ²	0.0150
Equivalent Cas air load	Vas	m ³	0.0040
Max linear excursion	Xmax	mm	± 2.5
Linear displacement volume	Vd	10 ⁻³ .m ³	0.0374
Reference efficiency	η ₀	%	2.2
Unity load volume	Vas.Qts ²	10 ⁻³ .m ³	0.4

Absolute maximum ratings

Short term max. input voltage	Vmax	V	90
Max.excursion before damage	Xdam	mm	± 3.0
Ambient operating temperature	Ta	°C	-10 to +50
Storage temperature		°C	-20 to +70
Environmental withstanding			tropical

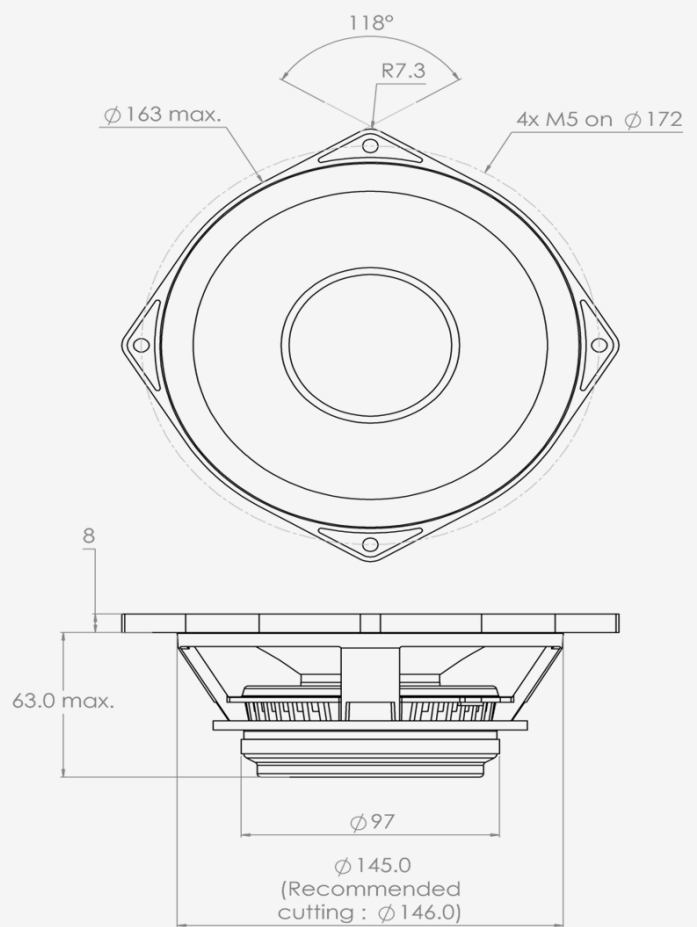

Mounting information

Air volume occupied by the driver	10 ⁻³ .m ³	0.40
Speaker net mass	kg	1.50
Baffle cut-out diameter (front mounting)	mm	146.0
Bolt number & Metric diameter	-	4x M5
Bolt circle diameter	mm	172.0
Max overall dimension (on ears)	mm	187.5
Max overall dimension (out of ears)	mm	162.5
Flange height	mm	8.0
Max magnet diameter	mm	97.5
Max depth (front mounting)	mm	63.0
Recommended reflex box	Lts / Hz	-
Electrical connection		6.35x0.8 FASTON



1660NdM

6.5" midrange driver

SPL curves measured on CEI standard baffle :

- . at 25 cm, normalised 1 m
- . at 1 m for reference
- . Graph amplitude = 60 dB (PHL Audio standard)

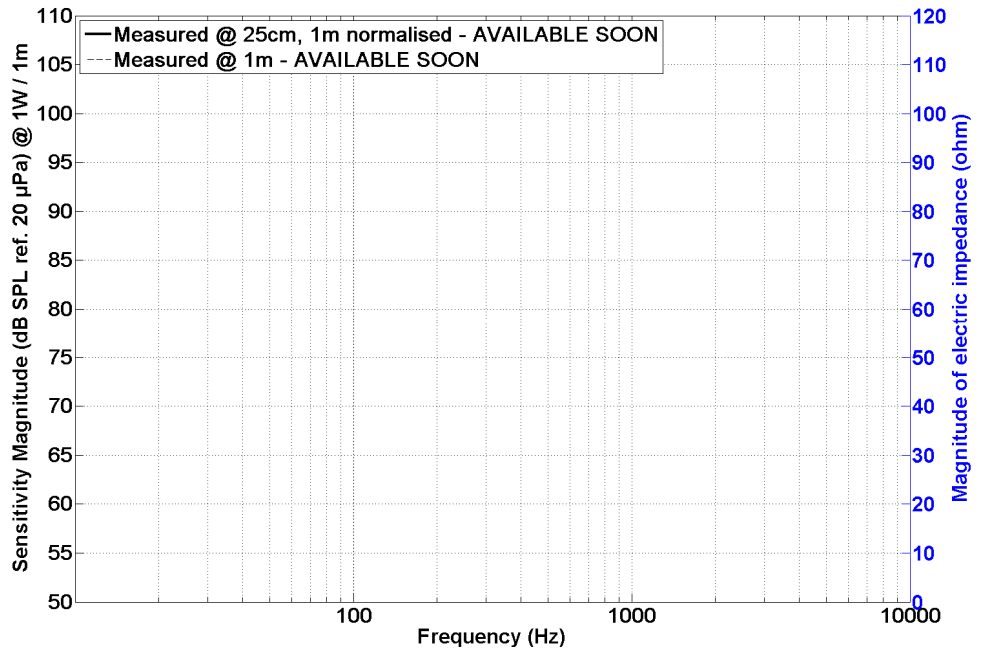

HD curve measured on CEI standard baffle :

- . at 1 meter
- . at power = $P_{AES} / 4$
- . Graph amplitude 0.01 % to 100 % (PHL Audio standard for $P_{AES}/4$)

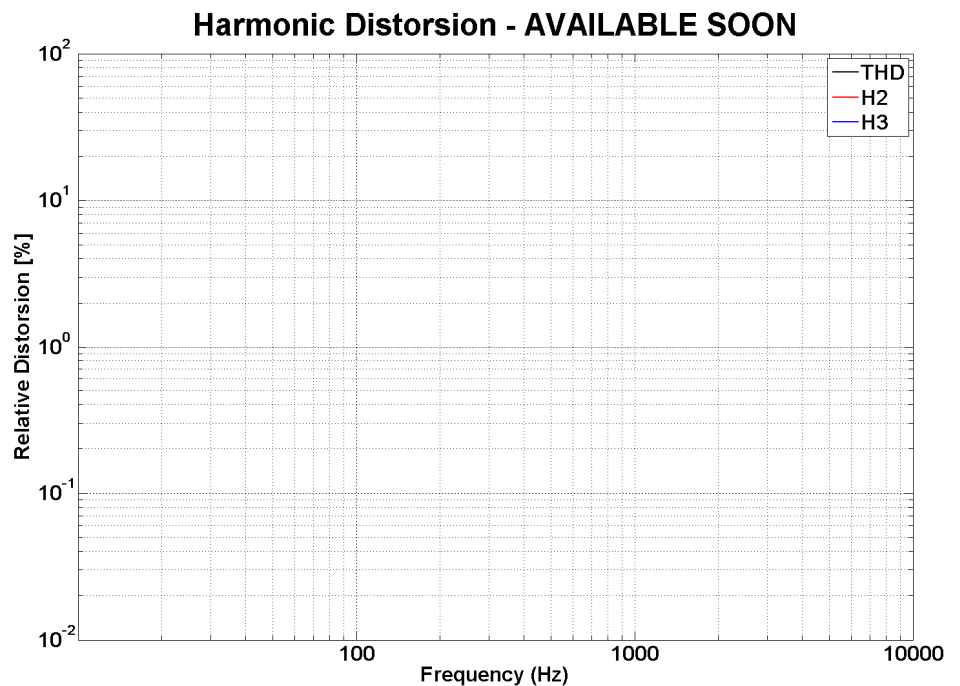

Non linear curves measured thanks to Klippel software and hardware, in free air

