

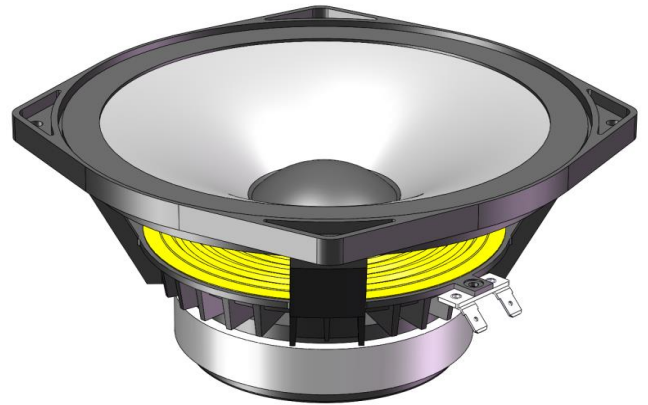

2040

Nominal Diameter	8 " / 20 cm
Rated Impedance	8
Sensitivity	94.5 dB SPL
Power Handling Capacity	120 W AES
SPL max (continuous)	111 dB SPL
Usable frequency range	200 - 5000 Hz
Speaker net mass	2.5 kg

8 inches midrange driver



Architecture highlights :

- Midrange unit with critical damping diaphragm
- Natural convection Intercooler System
- One side coated diaphragm (Humidity proof withstanding)

Motor architecture

Magnet material	-	Fe
Voice coil diameter	mm	38
Voice coil length	mm	12
Air gap height	mm	6

Typical characteristics

Rated impedance	Z	Ω	8
Half space sensitivity (1W@1m)	-	dB SPL	94.5
Usable freq. range	-	Hz	200 - 5000
Power handling capacity (AES)	-	W	120
Max Sound Pressure Level	SPL _{max}	dB SPL	111
Min. impedance modulus	Z _{min}	Ω@Hz	6.3@330
Voice-coil inductance @ 1kHz	Le _{1k}	mH	1.850
Voice-coil inductance @ 10kHz	Le _{10k}	mH	0.438
BL product	BL	N/A	8.5
Moving mass	M _{ms}	kg	0.0158

Thiele-Small parameters

Resonance frequency	F _s	Hz	119 (±11)
DC Resistance	Re	Ω	5.6 (±0.6)
Mechanical quality factor	Q _{ms}	1	4.71
Electrical quality factor	Q _{es}	1	0.91
Total quality factor	Q _{ts}	1	0.76
Suspension compliance	C _{ms}	10 ⁻⁶ .m/N	110
Effective piston area	S _d	m ²	0.0241
Equivalent Cas air load	V _{as}	m ³	0.0093
Max linear excursion	X _{max}	mm	± 2.0
Linear displacement volume	V _d	10 ⁻³ .m ³	0.0481
Reference efficiency	η ₀	%	1.7
Unity load volume	V _{as} .Q _{ts} ²	10 ⁻³ .m ³	5.5

Absolute maximum ratings

Short term max. input voltage	V _{max}	V	60
Max.excursion before damage	X _{dam}	mm	± 4.0
Ambient operating temperature	T _a	°C	-10 to +50
Storage temperature		°C	-20 to +70
Environmental withstanding			Humidity proof

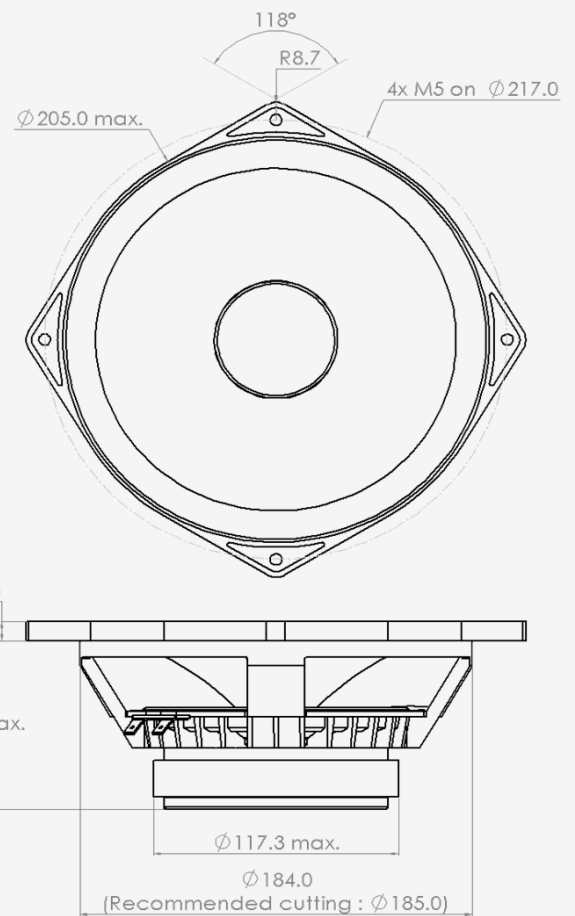

Mounting information

Air volume occupied by the driver	10 ⁻³ .m ³	0.61
Speaker net mass	kg	2.50
Baffle cut-out diameter (front mounting)	mm	185.0
Bolt number & Metric diameter	-	4x M5
Bolt circle diameter	mm	217.0
Max overall dimension (on ears)	mm	234.0
Max overall dimension (out of ears)	mm	205.0
Flange height	mm	9.5
Max magnet diameter	mm	117.3
Max depth (front mounting)	mm	83.5
Recommended reflex box	Lts / Hz	-
Electrical connection		6.3x0.8 Faston



2040

8 inches midrange driver

SPL curves measured on CEI standard baffle :

- . at 25 cm, normalised 1 m
- . at 1 m for reference
- . Graph amplitude = 60 dB (PHL Audio standard)



HD curve measured on CEI standard baffle :

- . at 1 meter
- . at power = $P_{AES} / 4$
- . Graph amplitude 0.01 % to 100 % (PHL Audio standard for $P_{AES}/4$)

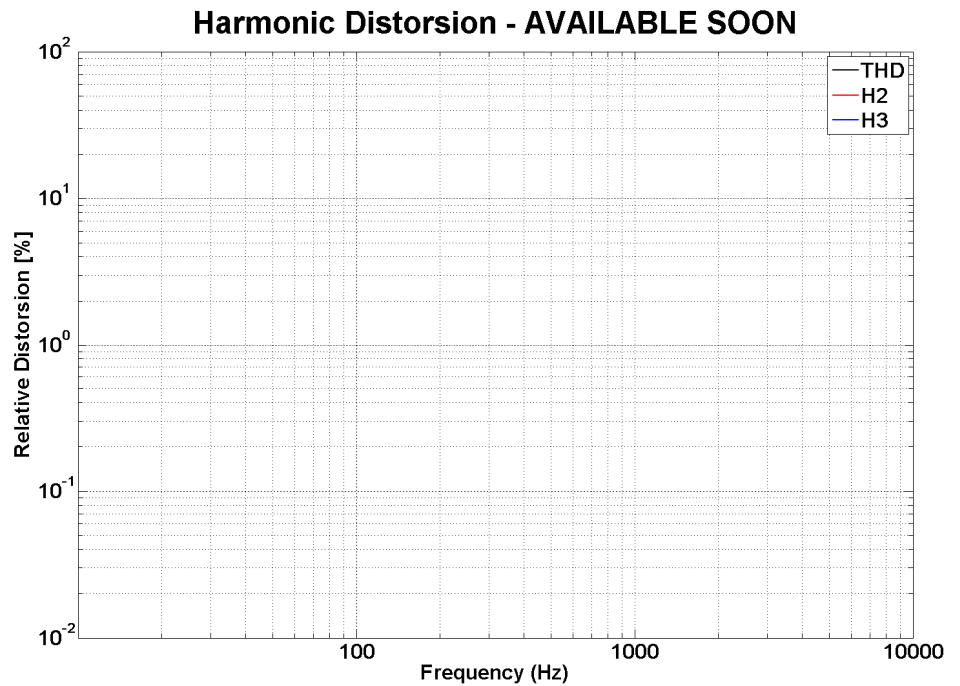

Non linear curves measured thanks to Klippel software and hardware, in free air

