

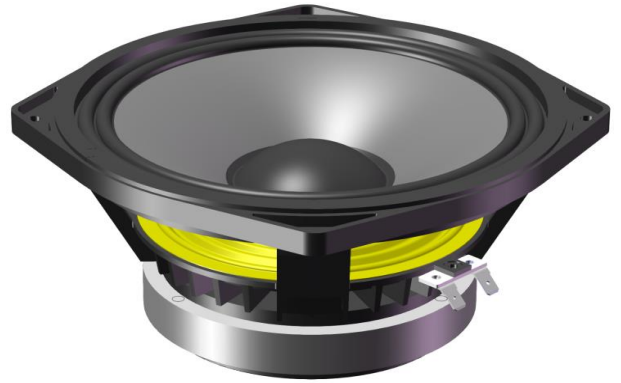

## 2420

Nominal Diameter	8 " / 20 cm
Rated Impedance	8
Sensitivity	93.5 dB SPL
Power Handling Capacity	200 W AES
SPL max (continuous)	113 dB SPL
Usable frequency range	70 - 3000 Hz
Speaker net mass	3.02 kg

## 8 inches low-mid driver



### Architecture highlights :

- Natural convection Intercooler System
- High compliance double half-roll Fabric Surround

### Motor architecture

Magnet material	-	Fe
Voice coil diameter	mm	51
Voice coil length	mm	14
Air gap height	mm	6

### Typical characteristics

Rated impedance	Z	Ω	8
Half space sensitivity (1W@1m)	-	dB SPL	93.5
Usable freq. range	-	Hz	70 - 3000
Power handling capacity (AES)	-	W	200
Max Sound Pressure Level	SPL <sub>max</sub>	dB SPL	113
Min. impedance modulus	Z <sub>min</sub>	Ω@Hz	5.6@370
Voice-coil inductance @ 1kHz	Le <sub>1k</sub>	mH	0.896
Voice-coil inductance @ 10kHz	Le <sub>10k</sub>	mH	0.405
BL product	BL	N/A	12.9
Moving mass	M <sub>ms</sub>	kg	0.0250

### Thiele-Small parameters

Resonance frequency	F <sub>s</sub>	Hz	72 (±10)
DC Resistance	R <sub>e</sub>	Ω	5.4 (±0.5)
Mechanical quality factor	Q <sub>ms</sub>	1	3.77
Electrical quality factor	Q <sub>es</sub>	1	0.37
Total quality factor	Q <sub>ts</sub>	1	0.33
Suspension compliance	C <sub>ms</sub>	10 <sup>-6</sup> .m/N	200
Effective piston area	S <sub>d</sub>	m <sup>2</sup>	0.0219
Equivalent Cas air load	V <sub>as</sub>	m <sup>3</sup>	0.0133
Max linear excursion	X <sub>max</sub>	mm	± 5.5
Linear displacement volume	V <sub>d</sub>	10 <sup>-3</sup> .m <sup>3</sup>	0.1205
Reference efficiency	η <sub>0</sub>	%	1.3
Unity load volume	V <sub>as</sub> .Q <sub>ts</sub> <sup>2</sup>	10 <sup>-3</sup> .m <sup>3</sup>	1.5

### Absolute maximum ratings

Short term max. input voltage	V <sub>max</sub>	V	80
Max. excursion before damage	X <sub>dam</sub>	mm	± 13.0
Ambient operating temperature	T <sub>a</sub>	°C	-10 to +50
Storage temperature		°C	-20 to +70
Environmental withstanding			Humidity proof

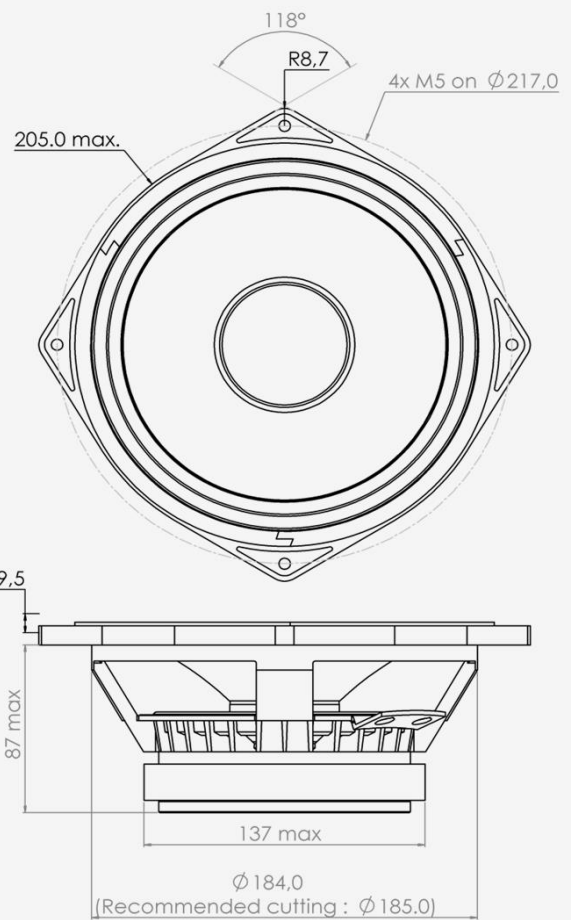

### Mounting information

Air volume occupied by the driver	10 <sup>-3</sup> .m <sup>3</sup>	0.72
Speaker net mass	kg	3.02
Baffle cut-out diameter (front mounting)	mm	185.0
Bolt number & Metric diameter	-	4x M5
Bolt circle diameter	mm	217.0
Max overall dimension (on ears)	mm	234.0
Max overall dimension (out of ears)	mm	205.0
Flange height	mm	9.5
Max magnet diameter	mm	137.0
Max depth (front mounting)	mm	87.0
Recommended reflex box	Lts / Hz	-
Electrical connection		6.3x0.8 Faston



2420

8 inches low-mid driver

SPL curves measured on CEI standard baffle :

- . at 25 cm, normalised 1 m
- . at 1 m for reference
- . Graph amplitude = 60 dB (PHL Audio standard)

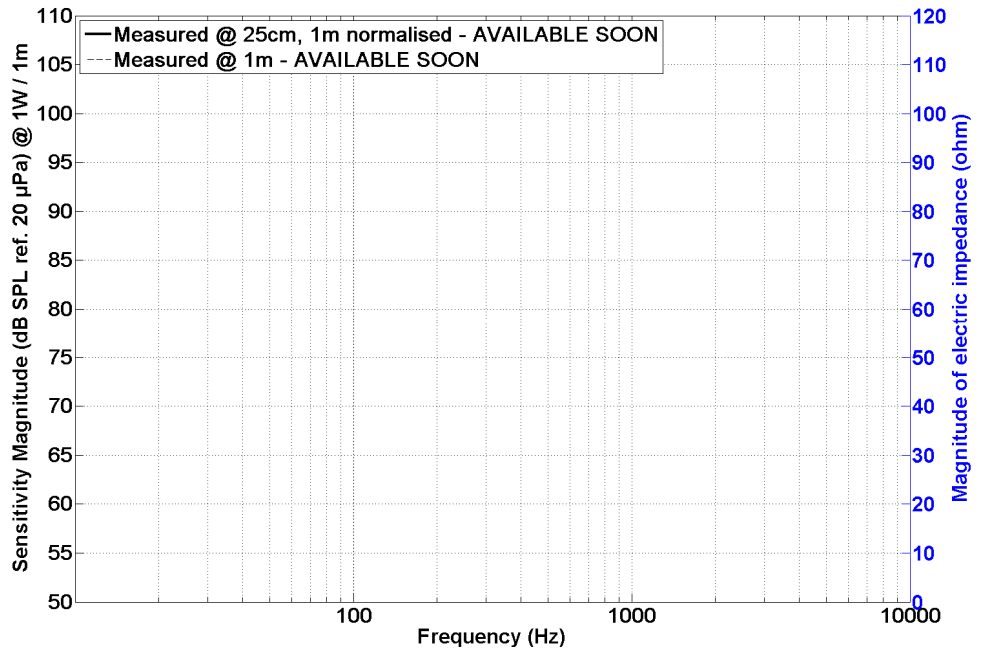

HD curve measured on CEI standard baffle :

- . at 1 meter
- . at power =  $P_{AES} / 4$
- . Graph amplitude 0.01 % to 100 % (PHL Audio standard for  $P_{AES}/4$ )

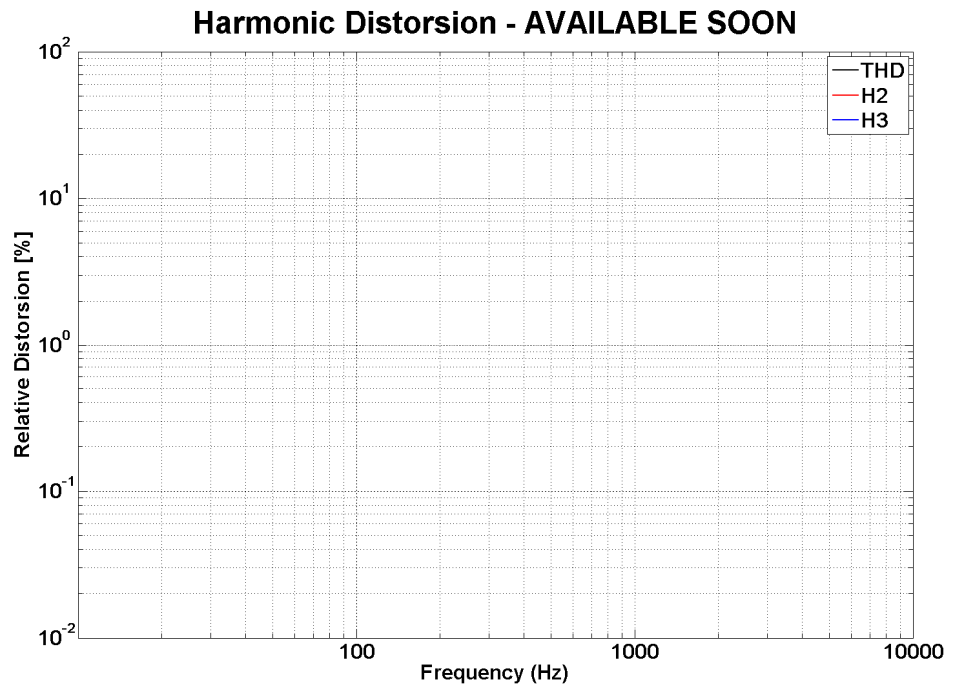

Non linear curves measured thanks to Klippel software and hardware, in free air

