



3481-14

Nominal Diameter	10 " / 25 cm
Rated Impedance	8
Sensitivity	94 dB SPL
Power Handling Capacity	250 W AES
SPL max (continuous)	114 dB SPL
Usable frequency range	40-3000 Hz
Speaker net mass	5.9 kg

10" bass driver / 1" coaxial



Architecture highlights :

- Noiseless natural convection Intercooling System
- High compliance double half-roll Fabric Surround for low Fs
- Dual side coated diaphragm
- Coaxial apparatus "1"-14" with rear flange
(Max diameter for HF driver = 136.0 mm)

Motor architecture

Magnet material	-	Fe
Voice coil diameter	mm	64
Voice coil length	mm	17
Air gap height	mm	8

Typical characteristics

Rated impedance	Z	Ω	8
Half space sensitivity (1W@1m)	-	dB SPL	94.0
Usable freq. range	-	Hz	40-3000
Power handling capacity (AES)	-	W	250
Max Sound Pressure Level	SPL _{max}	dB SPL	114
Min. impedance modulus	Z _{min}	Ω@Hz	7@300
Voice-coil inductance @ 1kHz	Le _{1k}	mH	0.722
Voice-coil inductance @ 10kHz	Le _{10k}	mH	0.485
BL product	BL	N/A	18.1
Moving mass	Mms	kg	0.0495

Thiele-Small parameters

Resonance frequency	Fs	Hz	55 (±7)
DC Resistance	Re	Ω	5.2 (±0.5)
Mechanical quality factor	Qms	1	6.56
Electrical quality factor	Qes	1	0.27
Total quality factor	Qts	1	0.26
Suspension compliance	Cms	10 ⁻⁶ .m/N	170
Effective piston area	Sd	m ²	0.0324
Equivalent Cas air load	Vas	m ³	0.0252
Max linear excursion	Xmax	mm	± 6.0
Linear displacement volume	Vd	10 ⁻³ .m ³	0.1942
Reference efficiency	η ₀	%	1.5
Unity load volume	Vas.Qts ²	10 ⁻³ .m ³	1.7

Absolute maximum ratings

Short term max. input voltage	Vmax	V	90
Max.excursion before damage	Xdam	mm	± 12.0
Ambient operating temperature	Ta	°C	-10 to +50
Storage temperature		°C	-20 to +70
Environmental withstanding			Tropical

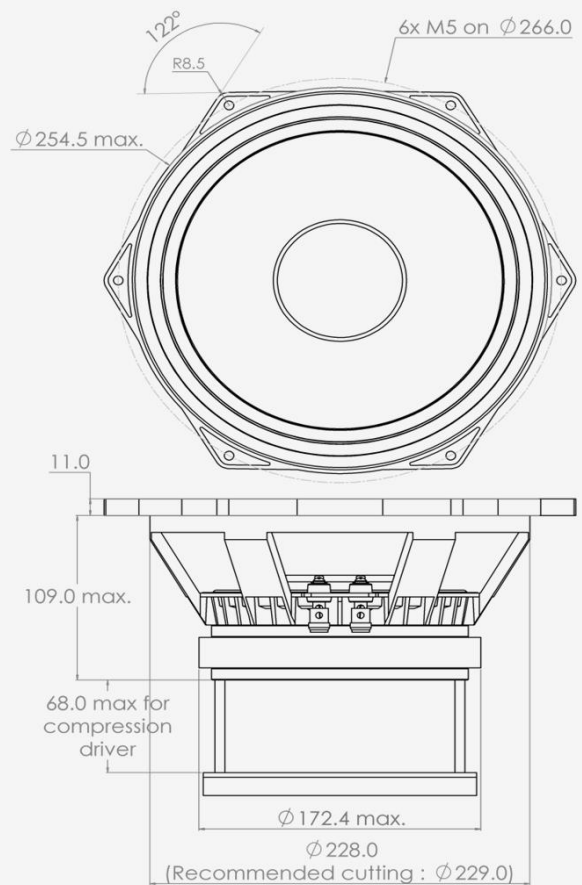

Mounting information

Air volume occupied by the driver	10 ⁻³ .m ³	1.50
Speaker net mass	kg	5.90
Baffle cut-out diameter (front mounting)	mm	229.0
Bolt number & Metric diameter	-	6x M5
Bolt circle diameter	mm	266.0
Max overall dimension (on ears)	mm	283.5
Max overall dimension (out of ears)	mm	254.5
Flange height	mm	11.0
Max magnet diameter	mm	172.4
Max depth (front mounting)	mm	109.0
Recommended reflex box	Lts / Hz	-
Electrical connection		Ø4 mm Push buttons



3481-14

10" bass driver / 1" coaxial

SPL curves measured on CEI standard baffle :

- . at 25 cm, normalised 1 m
- . at 1 m for reference
- . Graph amplitude = 60 dB (PHL Audio standard)



HD curve measured on CEI standard baffle :

- . at 1 meter
- . at power = $P_{AES} / 4$
- . Graph amplitude 0.01 % to 100 % (PHL Audio standard for $P_{AES}/4$)

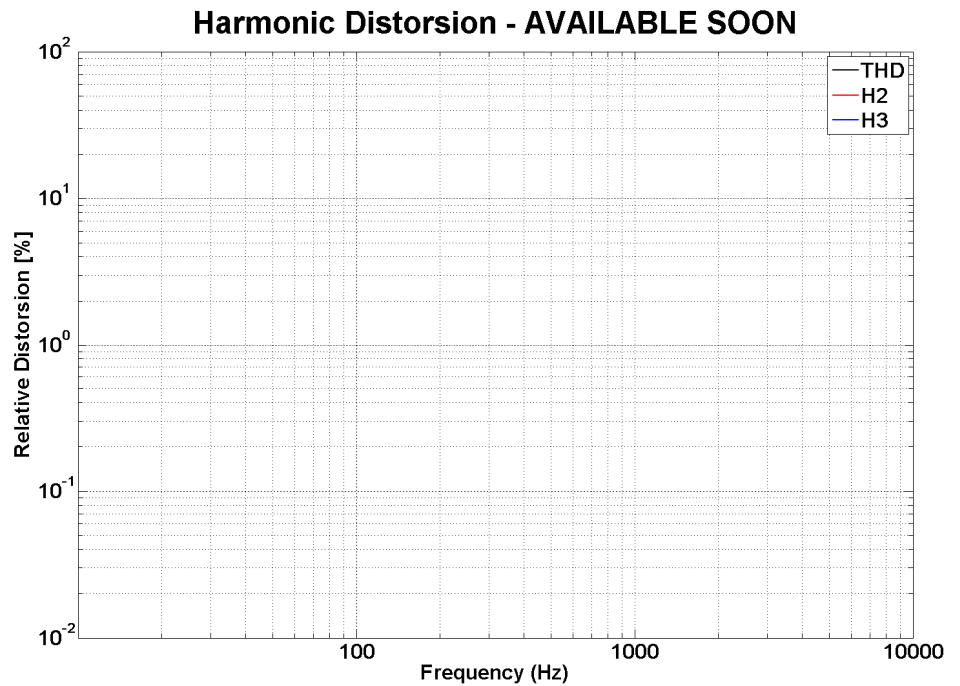

Non linear curves measured thanks to Klippel software and hardware, in free air

