

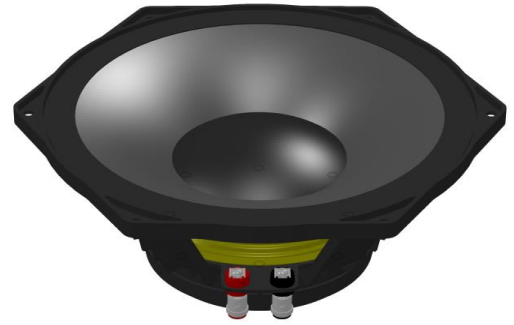

3860NdSM

Nominal Diameter	10 " / 25 cm
Rated Impedance	8
Sensitivity	100 dB SPL
Power Handling Capacity	250 W AES
SPL max (continuous)	121 dB SPL
Usable frequency range	120 - 3000 Hz
Speaker net mass	4.3 kg

10 inches midrange driver



Architecture highlights :

- Very high sensitivity & SPLmax 10" Midrange driver with low THD level
- Midrange unit with critical damping diaphragm
- High definition CCAR vented voice-coil
- Neodymium magnet system with symmetric BL(x) and Le(x)
- Natural convection Intercooler System
- Low profile with flat motor

Motor architecture

Magnet material	-	Nd
Voice coil diameter	mm	77
Voice coil length	mm	12
Air gap height	mm	10

Typical characteristics

Rated impedance	Z	Ω	8
Half space sensitivity (1W@1m)	-	dB SPL	100.0
Usable freq. range	-	Hz	120 - 3000
Power handling capacity (AES)	-	W	250
Max Sound Pressure Level	SPL _{max}	dB SPL	121
Min. impedance modulus	Z _{min}	Ω@Hz	6.7@550
Voice-coil inductance @ 1kHz	Le _{1k}	mH	-
Voice-coil inductance @ 10kHz	Le _{10k}	mH	-
BL product	BL	N/A	25.2
Moving mass	Mms	kg	0.0380

Thiele-Small parameters

Resonance frequency	Fs	Hz	90 (±18)
DC Resistance	Re	Ω	5.5 (±0.6)
Mechanical quality factor	Qms	1	2.98
Electrical quality factor	Qes	1	0.19
Total quality factor	Qts	1	0.18
Suspension compliance	Cms	10 ⁻⁶ .m/N	80
Effective piston area	Sd	m ²	0.0377
Equivalent Cas air load	Vas	m ³	0.0165
Max linear excursion	Xmax	mm	± 2.5
Linear displacement volume	Vd	10 ⁻³ .m ³	0.0942
Reference efficiency	η ₀	%	6.3
Unity load volume	Vas.Qts ²	10 ⁻³ .m ³	0.5

Absolute maximum ratings

Short term max. input voltage	Vmax	V	90
Max.excursion before damage	Xdam	mm	± 4.0
Ambient operating temperature	Ta	°C	-10 to +50
Storage temperature		°C	-20 to +70
Environmental withstanding			Humidity proof

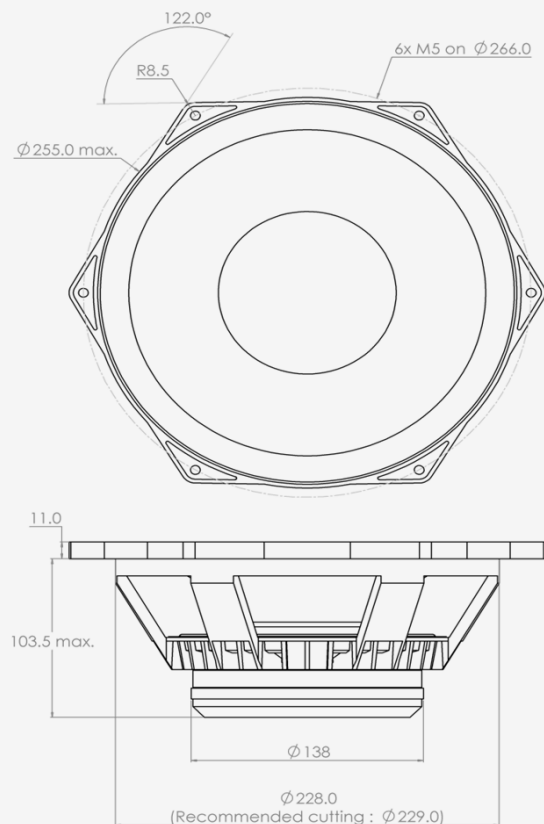

Mounting information

Air volume occupied by the driver	10 ⁻³ .m ³	1.30
Speaker net mass	kg	4.30
Baffle cut-out diameter (front mounting)	mm	229.0
Bolt number & Metric diameter	-	6x M5
Bolt circle diameter	mm	266.0
Max overall dimension (on ears)	mm	283.5
Max overall dimension (out of ears)	mm	255.0
Flange height	mm	11.0
Max magnet diameter	mm	140.0
Max depth (front mounting)	mm	103.5
Recommended reflex box	Lts / Hz	-
Electrical connection		Ø4 mm Push buttons



3860NdSM

10 inches midrange driver

SPL curves measured on CEI standard baffle :

- . at 25 cm, normalised 1 m
- . at 1 m for reference
- . Graph amplitude = 60 dB (PHL Audio standard)

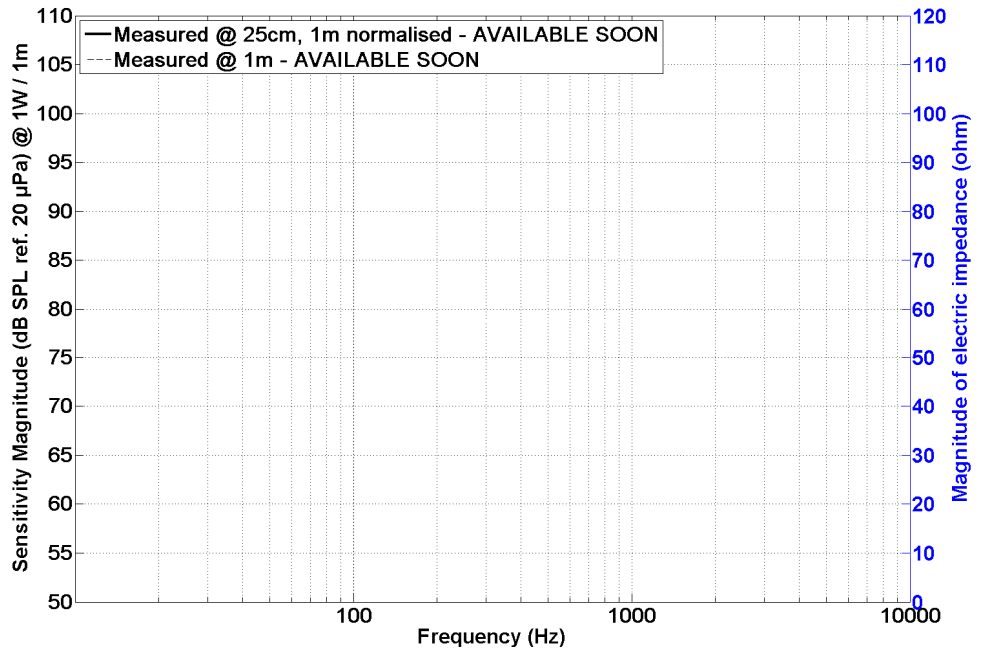

HD curve measured on CEI standard baffle :

- . at 1 meter
- . at power = $P_{AES} / 4$
- . Graph amplitude 0.01 % to 100 % (PHL Audio standard for $P_{AES}/4$)

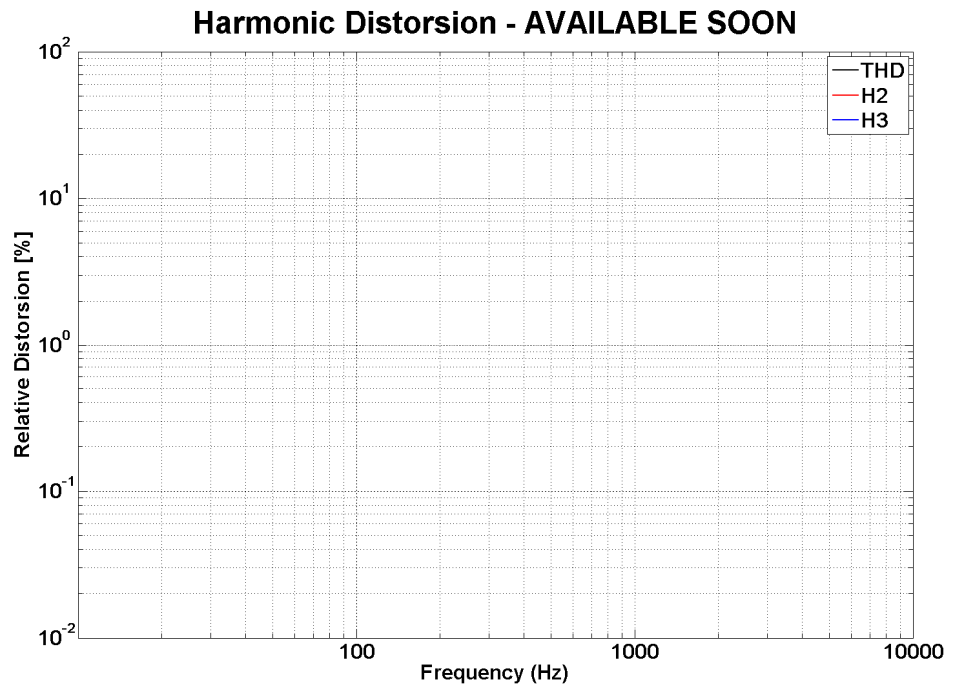

Non linear curves measured thanks to Klippel software and hardware, in free air

