

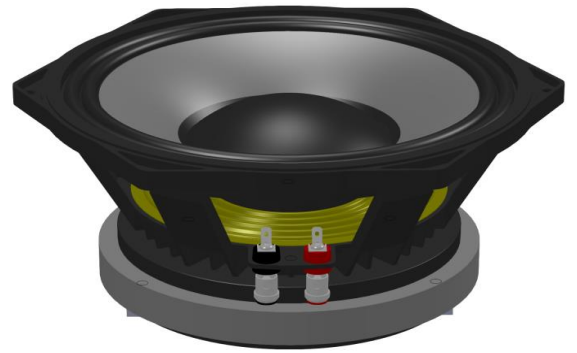

3900-2

Nominal Diameter	10 " / 25 cm
Rated Impedance	8
Sensitivity	95 dB SPL
Power Handling Capacity	400 W AES
SPL max (continuous)	117 dB SPL
Usable frequency range	50 - 2500 Hz
Speaker net mass	8.2 kg

10 inches bass driver / 1" coaxial



Architecture highlights :

1" Throat Coaxial Extended Unit
Natural convection Intercooler System

Motor architecture

Magnet material	-	Fe
Voice coil diameter	mm	77
Voice coil length	mm	17
Air gap height	mm	10

Typical characteristics

Rated impedance	Z	Ω	8
Half space sensitivity (1W@1m)	-	dB SPL	95.0
Usable freq. range	-	Hz	50 - 2500
Power handling capacity (AES)	-	W	400
Max Sound Pressure Level	SPL _{max}	dB SPL	117
Min. impedance modulus	Z _{min}	Ω @Hz	5.2@290
Voice-coil inductance @ 1kHz	Le _{1k}	mH	1.433
Voice-coil inductance @ 10kHz	Le _{10k}	mH	0.766
BL product	BL	N/A	22.7
Moving mass	M _{ms}	kg	0.0535

Thiele-Small parameters

Resonance frequency	F _s	Hz	56 (\pm 18)
DC Resistance	Re	Ω	5 (\pm 0.5)
Mechanical quality factor	Q _{ms}	1	4.71
Electrical quality factor	Q _{es}	1	0.18
Total quality factor	Q _{ts}	1	0.18
Suspension compliance	C _{ms}	10 ⁻⁶ .m/N	150
Effective piston area	S _d	m ²	0.0308
Equivalent Cas air load	V _{as}	m ³	0.0203
Max linear excursion	X _{max}	mm	\pm 4.5
Linear displacement volume	V _d	10 ⁻³ .m ³	0.1386
Reference efficiency	η_0	%	1.9
Unity load volume	V _{as} .Q _{ts} ²	10 ⁻³ .m ³	0.6

Absolute maximum ratings

Short term max. input voltage	V _{max}	V	110
Max.excursion before damage	X _{dam}	mm	\pm 12.0
Ambient operating temperature	T _a	$^{\circ}$ C	-10 to +50
Storage temperature		$^{\circ}$ C	-20 to +70
Environmental withstanding			Humidity proof

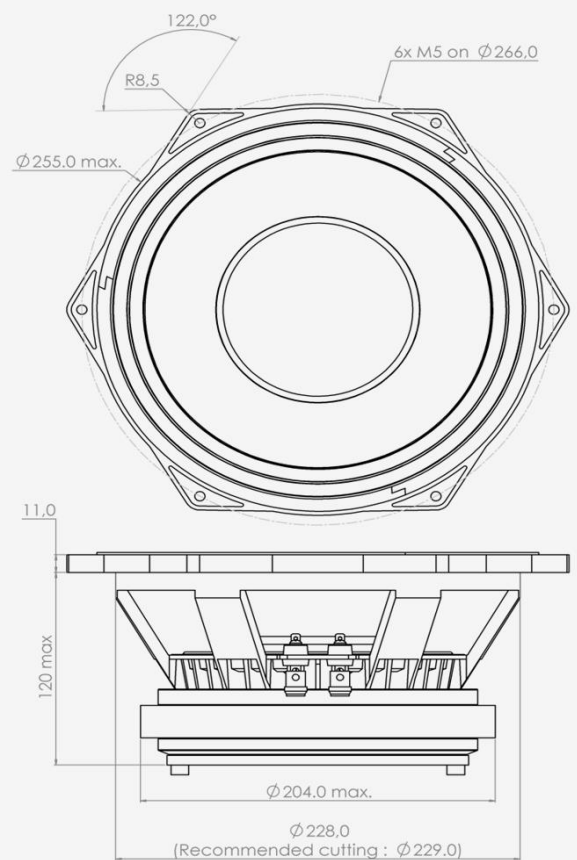

Mounting information

Air volume occupied by the driver	10 ⁻³ .m ³	2.00
Speaker net mass	kg	8.20
Baffle cut-out diameter (front mounting)	mm	229.0
Bolt number & Metric diameter	-	6x M5
Bolt circle diameter	mm	266.0
Max overall dimension (on ears)	mm	283.5
Max overall dimension (out of ears)	mm	255.0
Flange height	mm	11.0
Max magnet diameter	mm	204.0
Max depth (front mounting)	mm	120.0
Recommended reflex box	Lts / Hz	-
Electrical connection		\varnothing 4 mm Push buttons



3900-2

10 inches bass driver / 1" coaxial

SPL curves measured on CEI standard baffle :

- . at 25 cm, normalised 1 m
- . at 1 m for reference
- . Graph amplitude = 60 dB (PHL Audio standard)

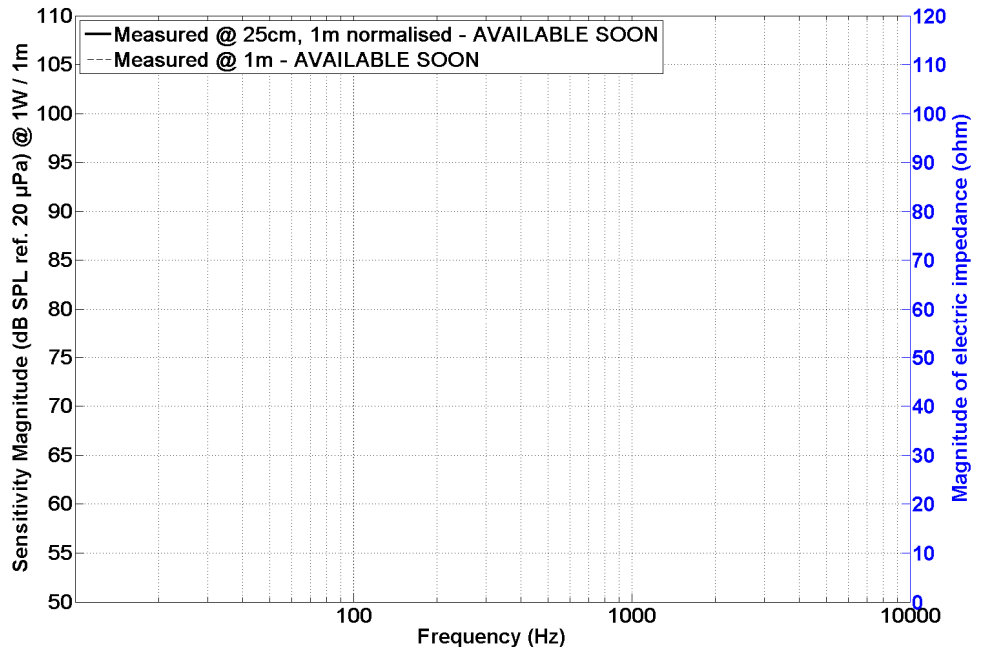

HD curve measured on CEI standard baffle :

- . at 1 meter
- . at power = $P_{AES} / 4$
- . Graph amplitude 0.01 % to 100 % (PHL Audio standard for $P_{AES}/4$)

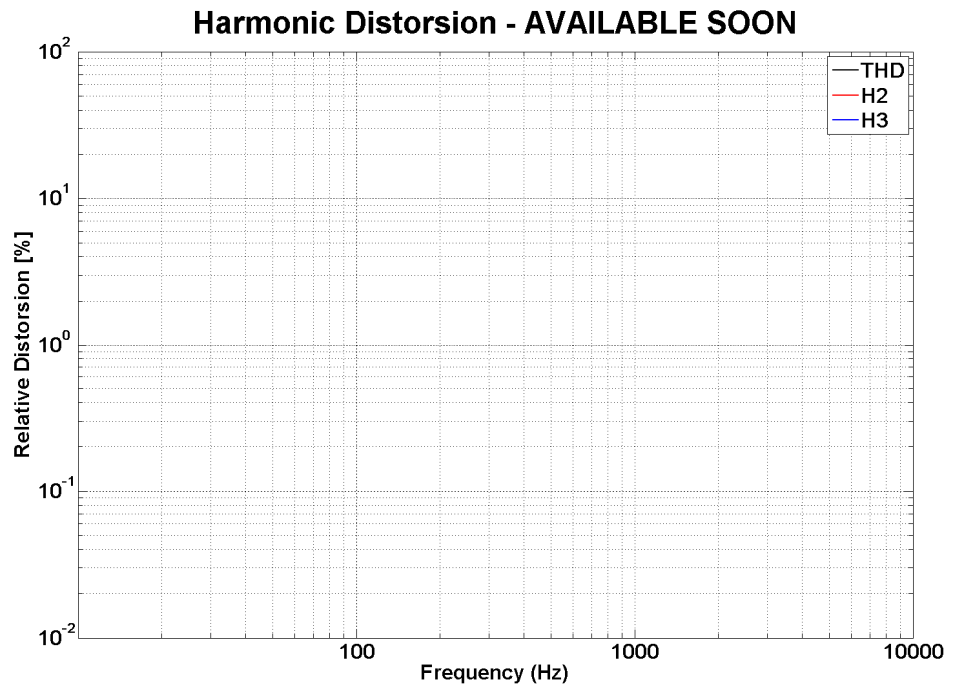

Non linear curves measured thanks to Klippel software and hardware, in free air

