

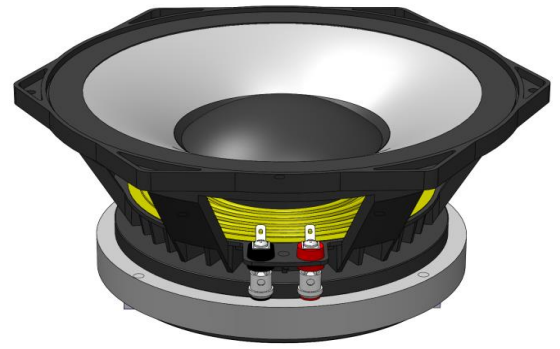

3960-5

Nominal Diameter	10 " / 25 cm
Rated Impedance	8
Sensitivity	97.5 dB SPL
Power Handling Capacity	250 W AES
SPL max (continuous)	117 dB SPL
Usable frequency range	120 - 3000 Hz
Speaker net mass	8.1 kg

10 inches midrange driver / 1.4" coaxial



Architecture highlights :

- 1.4" Throat Coaxial Extended Unit
- Very high sensitivity & SPLmax 10" Midrange driver with low THD level
- Midrange unit with critical damping diaphragm
- Natural convection Intercooler System

Motor architecture

Magnet material	-	Fe
Voice coil diameter	mm	77
Voice coil length	mm	12
Air gap height	mm	10

Typical characteristics

Rated impedance	Z	Ω	8
Half space sensitivity (1W@1m)	-	dB SPL	97.5
Usable freq. range	-	Hz	120 - 3000
Power handling capacity (AES)	-	W	250
Max Sound Pressure Level	SPL _{max}	dB SPL	117
Min. impedance modulus	Z _{min}	Ω@Hz	6.7@550
Voice-coil inductance @ 1kHz	Le _{1k}	mH	1.154
Voice-coil inductance @ 10kHz	Le _{10k}	mH	0.550
BL product	BL	N/A	21.1
Moving mass	M _{ms}	kg	0.0380

Thiele-Small parameters

Resonance frequency	F _s	Hz	90 (±18)
DC Resistance	Re	Ω	5.5 (±0.6)
Mechanical quality factor	Q _{ms}	1	2.98
Electrical quality factor	Q _{es}	1	0.27
Total quality factor	Q _{ts}	1	0.24
Suspension compliance	C _{ms}	10 ⁻⁶ .m/N	80
Effective piston area	S _d	m ²	0.0330
Equivalent Cas air load	V _{as}	m ³	0.0127
Max linear excursion	X _{max}	mm	± 2.5
Linear displacement volume	V _d	10 ⁻³ .m ³	0.0825
Reference efficiency	η ₀	%	3.4
Unity load volume	V _{as} .Q _{ts} ²	10 ⁻³ .m ³	0.8

Absolute maximum ratings

Short term max. input voltage	V _{max}	V	90
Max.excursion before damage	X _{dam}	mm	± 4.0
Ambient operating temperature	T _a	°C	-10 to +50
Storage temperature		°C	-20 to +70
Environmental withstanding			Humidity proof

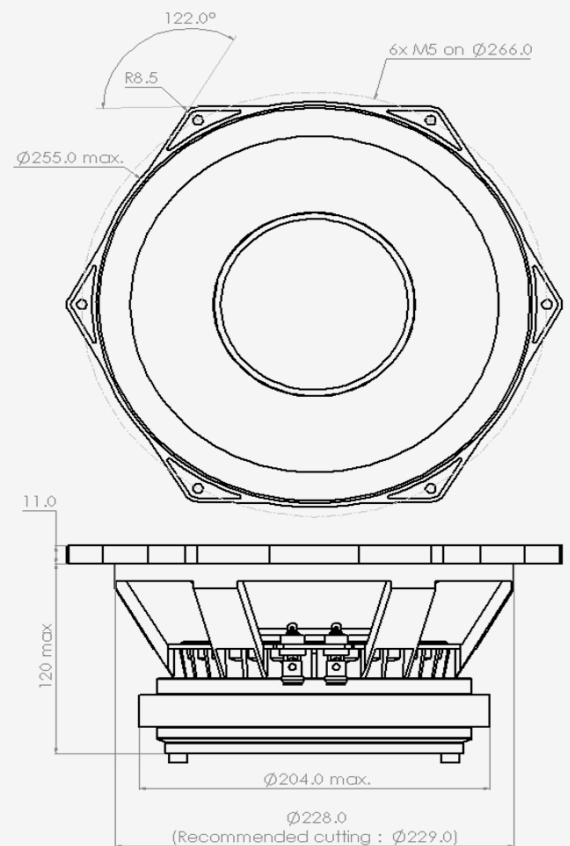

Mounting information

Air volume occupied by the driver	10 ⁻³ .m ³	2.30
Speaker net mass	kg	8.10
Baffle cut-out diameter (front mounting)	mm	229.0
Bolt number & Metric diameter	-	6x M5
Bolt circle diameter	mm	266.0
Max overall dimension (on ears)	mm	283.5
Max overall dimension (out of ears)	mm	255.0
Flange height	mm	11.0
Max magnet diameter	mm	204.0
Max depth (front mounting)	mm	120.0
Recommended reflex box	Lts / Hz	-
Electrical connection		Ø4 mm Push buttons



3960-5

1.4 inches midrange driver / 1.4" coaxial

SPL curves measured on CEI standard baffle :

- . at 25 cm, normalised 1 m
- . at 1 m for reference
- . Graph amplitude = 60 dB (PHL Audio standard)

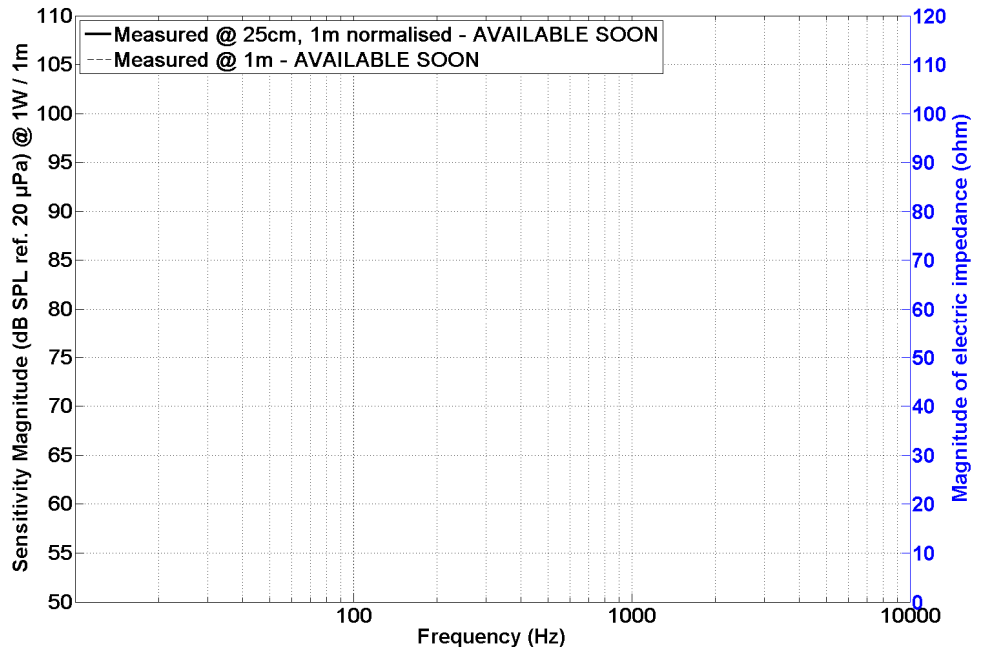

HD curve measured on CEI standard baffle :

- . at 1 meter
- . at power = $P_{AES} / 4$
- . Graph amplitude 0.01 % to 100 % (PHL Audio standard for $P_{AES}/4$)

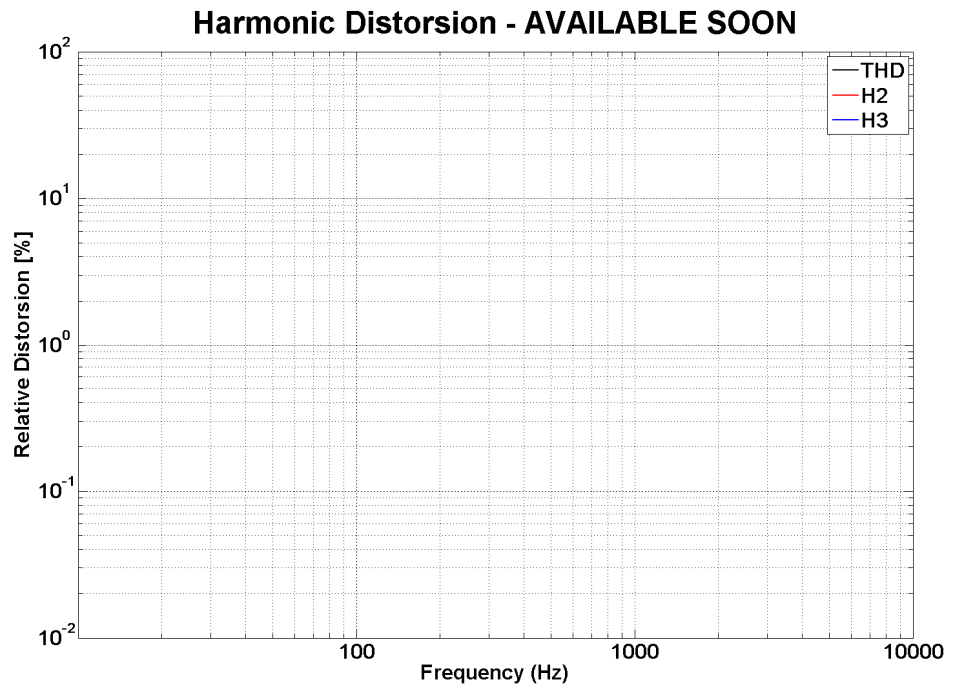

Non linear curves measured thanks to Klippel software and hardware, in free air

