



# 4031NdU

Nominal Diameter	12 " / 30 cm
Rated Impedance	8
Sensitivity	95 dB SPL
Power Handling Capacity	500 W AES
SPL max (continuous)	119 dB SPL
Usable frequency range	40 - 2000 Hz
Speaker net mass	6.3 kg

# 12 inches bass driver



## Architecture highlights :

- Natural convection Intercooling System
- Both sides coated Curvilinear cone (Tropical withstanding)
- High compliance double half-roll fabric surround

## Motor architecture

Magnet material	-	Nd
Voice coil diameter	mm	77
Voice coil length	mm	20
Air gap height	mm	10

## Typical characteristics

Rated impedance	Z	$\Omega$	8
Half space sensitivity (1W@1m)	-	dB SPL	95.0
Usable freq. range	-	Hz	40 - 2000
Power handling capacity (AES)	-	W	500
Max Sound Pressure Level	SPL <sub>max</sub>	dB SPL	119
Min. impedance modulus	Z <sub>min</sub>	$\Omega$ @Hz	6.9@260
Voice-coil inductance @ 1kHz	Le <sub>1k</sub>	mH	1.241
Voice-coil inductance @ 10kHz	Le <sub>10k</sub>	mH	0.572
BL product	BL	N/A	20.5
Moving mass	Mms	kg	0.0780

## Thiele-Small parameters

Resonance frequency	Fs	Hz	44 ( $\pm 6$ )
DC Resistance	Re	$\Omega$	5.6 ( $\pm 0.6$ )
Mechanical quality factor	Qms	1	5.36
Electrical quality factor	Qes	1	0.29
Total quality factor	Qts	1	0.27
Suspension compliance	Cms	10 <sup>-6</sup> .m/N	170
Effective piston area	Sd	m <sup>2</sup>	0.0539
Equivalent Cas air load	Vas	m <sup>3</sup>	0.0700
Max linear excursion	Xmax	mm	$\pm 7.5$
Linear displacement volume	Vd	10 <sup>-3</sup> .m <sup>3</sup>	0.4043
Reference efficiency	$\eta_0$	%	2.0
Unity load volume	Vas.Qts <sup>2</sup>	10 <sup>-3</sup> .m <sup>3</sup>	5.1

## Absolute maximum ratings

Short term max. input voltage	Vmax	V	125
Max.excursion before damage	Xdam	mm	$\pm 16.0$
Ambient operating temperature	Ta	$^{\circ}\text{C}$	-10 to +50
Storage temperature		$^{\circ}\text{C}$	-20 to +70
Environmental withstanding			Tropical

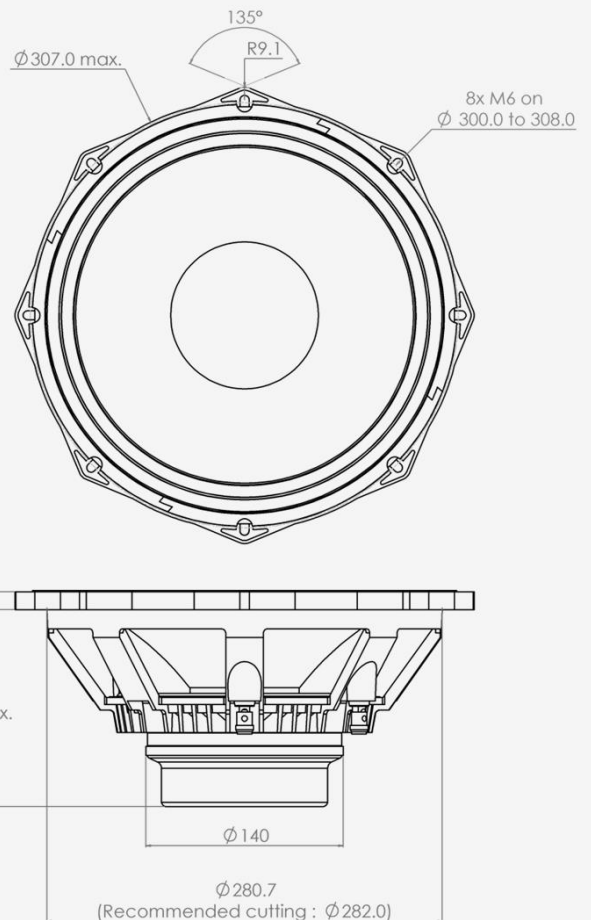

## Mounting information

Air volume occupied by the driver	10 <sup>-3</sup> .m <sup>3</sup>	2.10
Speaker net mass	kg	6.30
Baffle cut-out diameter (front mounting)	mm	282.0
Bolt number & Metric diameter	-	8x M6
Bolt circle diameter	mm	300 to 308
Max overall dimension (on ears)	mm	326.5
Max overall dimension (out of ears)	mm	307.0
Flange height	mm	12.8
Max magnet diameter	mm	140.0
Max depth (front mounting)	mm	141.5
Recommended reflex box	Lts / Hz	-
Electrical connection		$\varnothing 4$ mm Push buttons



# 4031NdU

# 12 inches bass driver

SPL curves measured on CEI standard baffle :

- . at 25 cm, normalised 1 m
- . at 1 m for reference
- . Graph amplitude = 60 dB (PHL Audio standard)

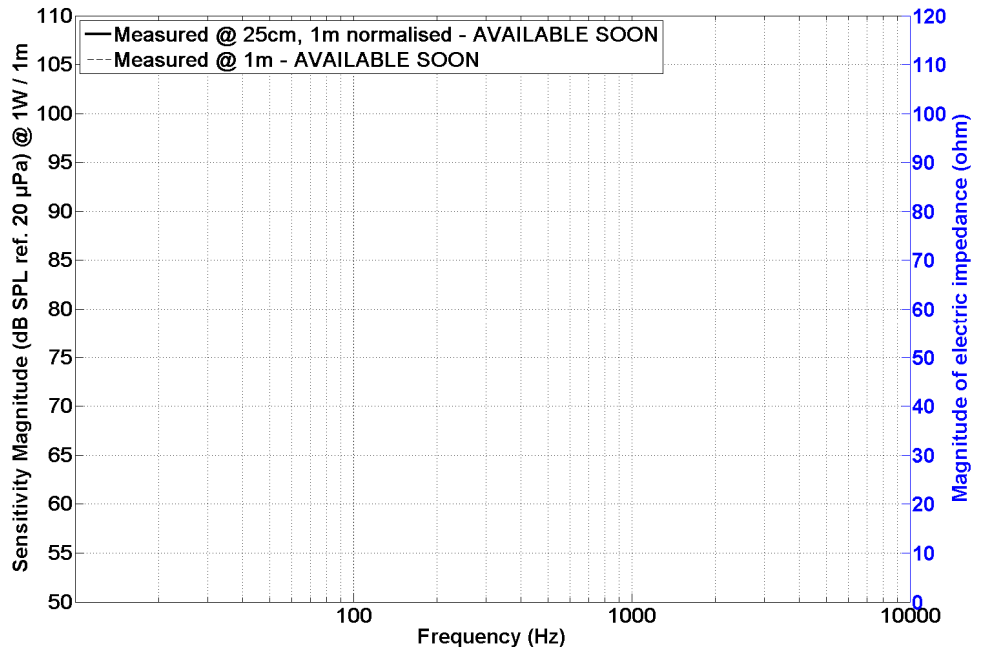

HD curve measured on CEI standard baffle :

- . at 1 meter
- . at power =  $P_{AES} / 4$
- . Graph amplitude 0.01 % to 100 % (PHL Audio standard for  $P_{AES}/4$ )

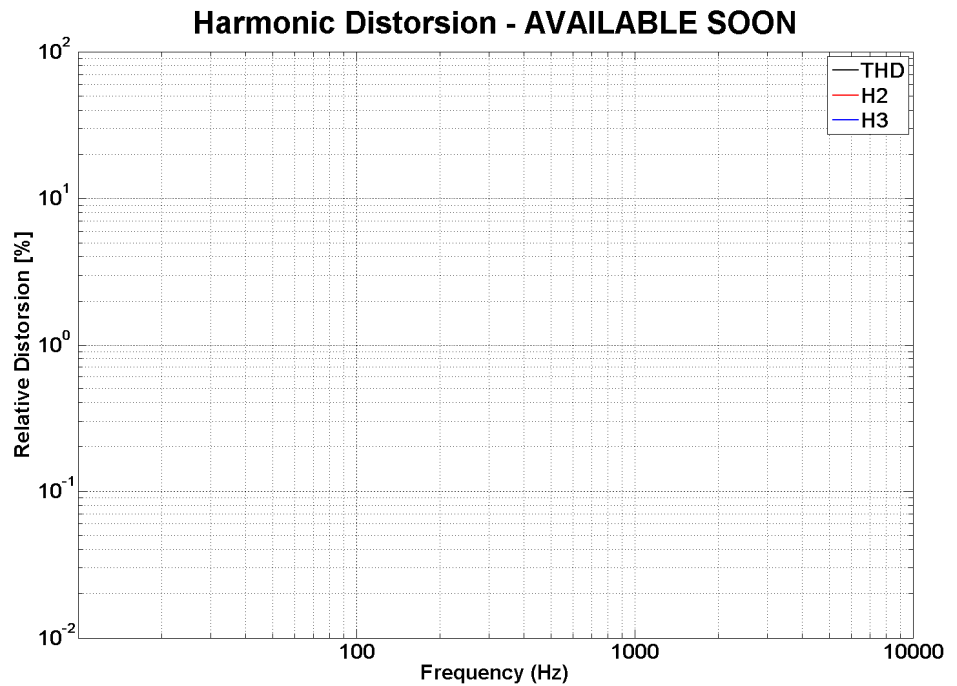

Non linear curves measured thanks to Klippel software and hardware, in free air

