



930

Nominal Diameter	5" / 13 cm
Rated Impedance	8
Sensitivity	92 dB SPL
Power Handling Capacity	100 W AES
SPL max (continuous)	108 dB SPL
Usable frequency range	110 - 4000 Hz
Speaker net mass	2.02 kg

5 inches low-mid driver



Architecture highlights :

- Noiseless natural convection Intercooling System
- Ferrite magnet system with symmetric $BL(x)$ and $Le(x)$
- High excursion fabric surround
- Lightweight basket

Motor architecture

Magnet material	-	Fe
Voice coil diameter	mm	38
Voice coil length	mm	12
Air gap height	mm	6

Typical characteristics

Rated impedance	Z	Ω	8
Half space sensitivity (1W@1m)	-	dB SPL	92.0
Usable freq. range	-	Hz	110 - 4000
Power handling capacity (AES)	-	W	100
Max Sound Pressure Level	SPL _{max}	dB SPL	108
Min. impedance modulus	Z _{min}	Ω @Hz	6.3@600
Voice-coil inductance @ 1kHz	Le _{1k}	mH	0.619
Voice-coil inductance @ 10kHz	Le _{10k}	mH	0.240
BL product	BL	N/A	8.7
Moving mass	Mms	kg	0.0092

Thiele-Small parameters

Resonance frequency	Fs	Hz	130 (± 20)
DC Resistance	Re	Ω	5.7 (± 0.6)
Mechanical quality factor	Qms	1	3.96
Electrical quality factor	Qes	1	0.57
Total quality factor	Qts	1	0.50
Suspension compliance	Cms	$10^{-6} \cdot \text{m/N}$	160
Effective piston area	Sd	m^2	0.0106
Equivalent Cas air load	Vas	m^3	0.0025
Max linear excursion	Xmax	mm	± 4.5
Linear displacement volume	Vd	$10^{-3} \cdot \text{m}^3$	0.0476
Reference efficiency	η_0	%	1.0
Unity load volume	Vas.Qts ²	$10^{-3} \cdot \text{m}^3$	0.6

Absolute maximum ratings

Short term max. input voltage	Vmax	V	55
Max. excursion before damage	Xdam	mm	± 9.0
Ambient operating temperature	Ta	$^{\circ}\text{C}$	-10 to +50
Storage temperature		$^{\circ}\text{C}$	-20 to +70
Environmental withstanding			Tropical

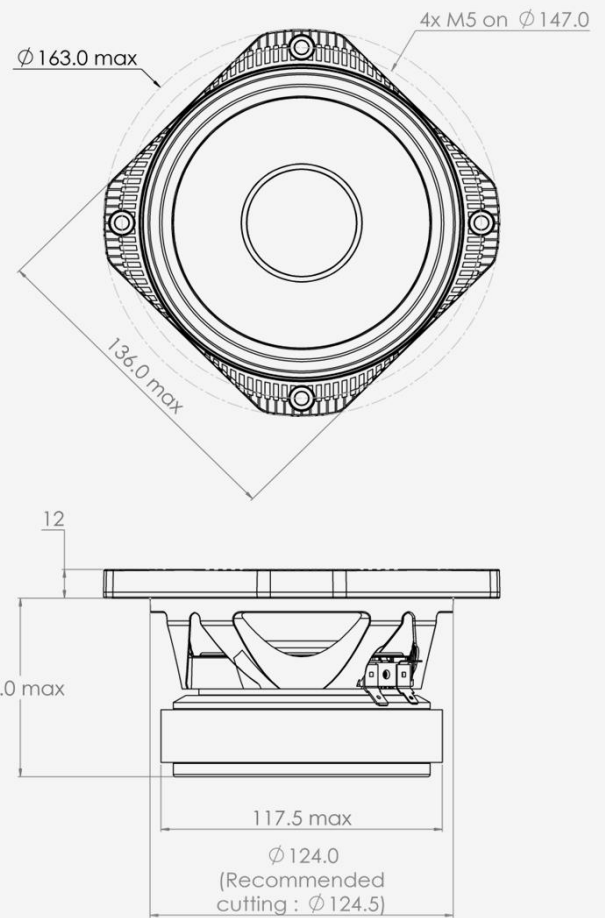

Mounting information

Air volume occupied by the driver	$10^{-3} \cdot \text{m}^3$	0.38
Speaker net mass	kg	2.02
Baffle cut-out diameter (front mounting)	mm	124.5
Bolt number & Metric diameter	-	4x M5
Bolt circle diameter	mm	147.0
Max overall dimension (on ears)	mm	163.0
Max overall dimension (out of ears)	mm	136.0
Flange height	mm	12.0
Max magnet diameter	mm	117.5
Max depth (front mounting)	mm	75.0
Recommended reflex box	Lts / Hz	-
Electrical connection		6.35x0.8 + 4.8x0.5 FASTON



SPL curves measured on CEI standard baffle :

- . at 25 cm, normalised 1 m
- . at 1 m for reference
- . Graph amplitude = 60 dB (PHL Audio standard)

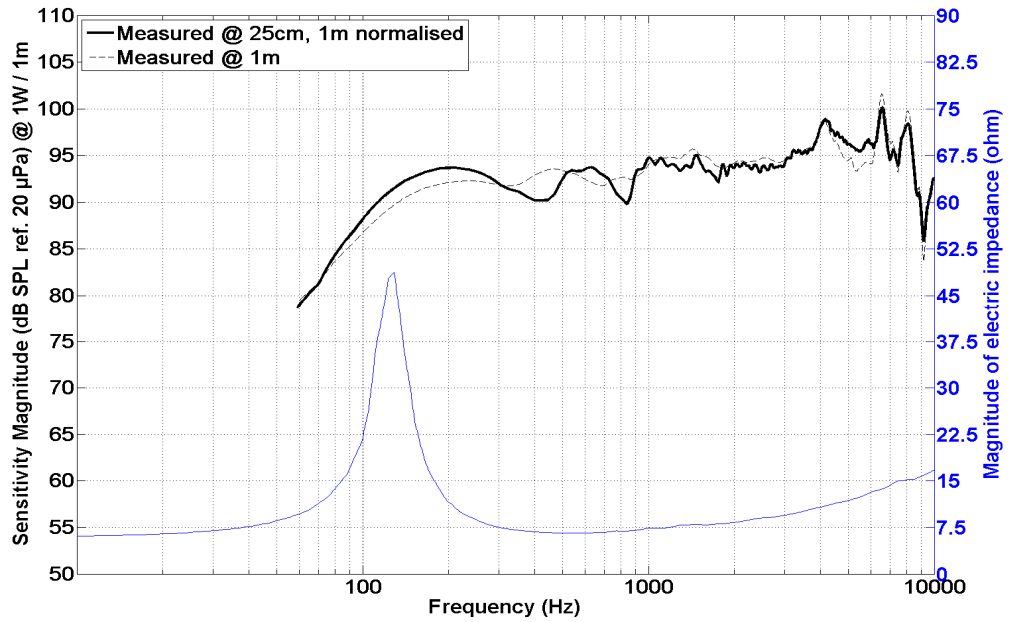

HD curve measured on CEI standard baffle :

- . at 1 meter
- . at power = $P_{AES} / 4$
- . Graph amplitude 0.01 % to 100 % (PHL Audio standard for $P_{AES}/4$)

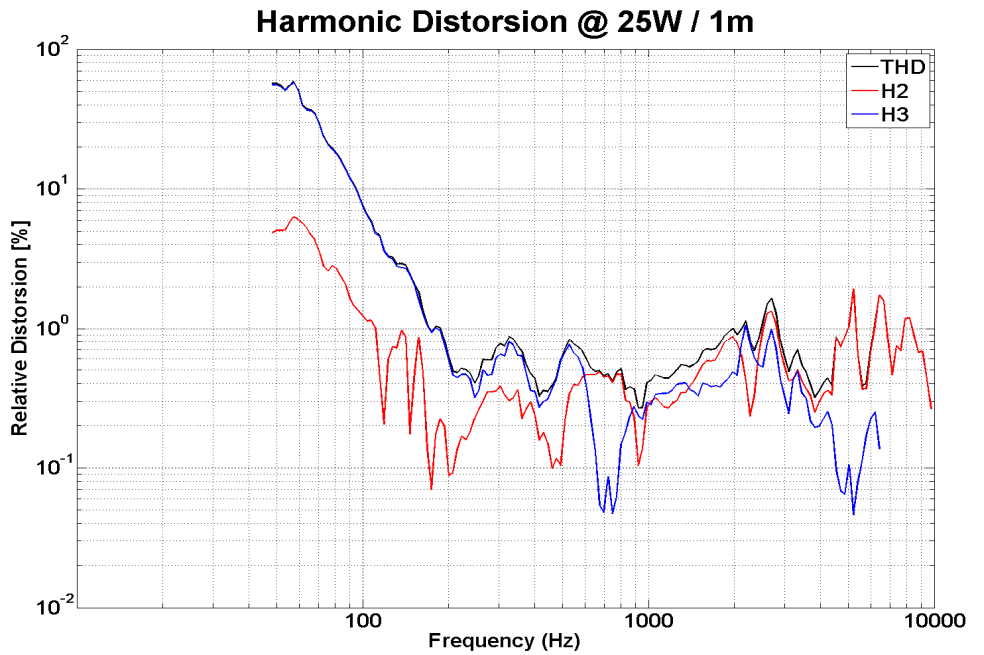

Non linear curves measured thanks to Klippel software and hardware, in free air

